

AUTO CHARGE 6012 and 4012

TRIPLE OUTPUT AUTOMATIC BATTERY CHARGER



Features

- Triple Battery Bank.
- Built-In Touch Screen Display.
- Dual Battery Type Technology – allows for two dissimilar battery chemistries charging at the same time.
- Can Bus enabled connectivity
- IP32 rated for greater ingress protection
- Parasitic Load Compensation (PLC) – allows for user input of total accessory load amps on the vehicle. This allows the charger to shift the absorption stage set point, so the battery voltage drops to the float voltage when desired current is reached.
- Configurable for 3-step or float charging.
- Optional Remote Touch Display Available.
- Accommodates Flooded, Gelled Electrolyte, AGM, Odyssey®, Lithium Iron Phosphate (LFP), and customized.
- Pump Plus (20A Aux) output
- Rotating mounting feet.

Outline Drawing

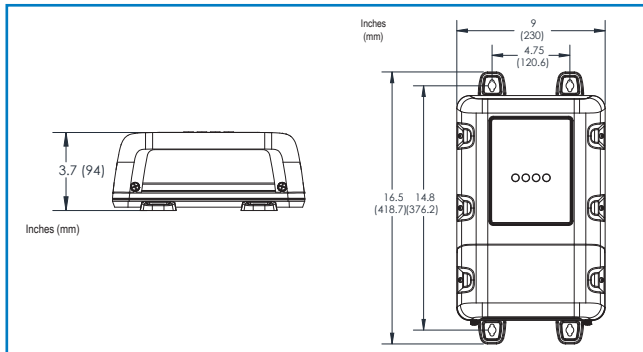

Remote Display Options

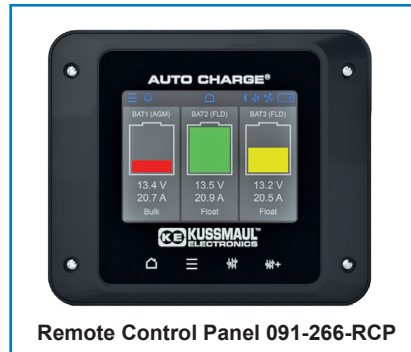

Specifications:

Part Number	Description	Electrical Data				Dimensions			Wt.
		DC Volts	DC Amps	AC Volts	AC Amps	L	W	H	
091-266-12-40	4012 with Integrated Display	12	40	120 - 240	6 - 3	16.5	9.0"	3.7	8.4 Lbs
091-266-12-40-RCP	4012 with Integrated Display + Remote Control Panel	12	40	120 - 240	6 - 3	16.5	9.0"	3.7	8.4 Lbs
091-266-12-60	6012 with Integrated Display	12	60	120 - 240	9 - 5	16.5	9.0"	3.7	8.4 Lbs
091-266-12-60-RCP	with Integrated Display + Remote Control Panel	12	60	120 - 240	9 - 5	16.5	9.0"	3.7	8.4 Lbs
091-266-RCP	Remote Control Panel					5.0"	4.2"	0.75"	1.3 Lbs